

## Development of the world's first fully-monolithic thermistor guaranteed for 200°C operation

Mitsubishi Materials Corporation (President: Akira Takeuchi, capitalization: 119.4 billion yen) has developed the world's first fully-monolithic structure<sup>\*1</sup> high temperature chip thermistor guaranteed to work in 200°C environments typical in or near an automobile's engine by using an electrically conductive adhesive<sup>\*2</sup> instead of conventional lead solder. Production starts in December 2016.

Electronic management of various sensing parts which use sensors to measure and affect systems has progressed in recent years to improve safety and effects on the environment in the automotive and industrial equipment markets. In particular, electronics which can be guaranteed to operate near engines and transmissions in harsh environments exceeding 150°C are particularly in demand. We responded to this need by developing our "TA Series High Temperature Chip Thermistor" which can be available in many sizes and can be used in small applications such as mobile phones all the way larger applications like power supplies, industrial motors, and automobiles.

High temperature chip thermistor features:

1. AEC-Q200<sup>\*3</sup> compliant for automotive powertrain or safety equipment
2. We developed a new AgPd (silver/palladium) external electrode to achieve high bonding reliability with conductive adhesive even at high temperatures. (fig. 2)
3. The monolithic structure and our uniquely developed thermistor material paired with our high reliability terminal electrode technology ensures excellent stability at high temperatures and the amount of resistance change is only 0.6% after a 2000 hour 250°C reliability test. (fig. 3) New small sizes will be available for miniaturization.

Mitsubishi Materials Electronic Materials Company promotes marketing-led research and development of high value-added products for our "Materials Premium 2016" medium-term management plan. We will continue to develop unique high value-added products that anticipate market needs and offer them to our customers.

- \*1. Fully monolithic structure means the thermistor is made of a single sintered composite oxide element which is coated by glass and has electrodes placed on the ends.
- \*2. Conductive adhesive relaxes the stress caused by thermal expansion and shrinkage of the PCB and the and allows for high reliability through many cycles of extreme temperature changes. It is environmentally friendly lead-free.
- \*3. AEC-Q200 is a requirement by the Automotive Electronics Council, which is an organization founded by major automobile manufacturers and US electronic suppliers for the standardization of automotive parts reliability testing.

## <New product specification>

1. Part number: TA05-3N333F (\*Additional resistance values will be added)
2. Size: 1005 size (1.0 x 0.5 x 0.5 mm)
3. Nominal resistance value @ 25°C:  $33\text{k}\Omega \pm 1.0\%$
4. Nominal B constant @ 25°C/50°C:  $3650\text{ K} \pm 1.0\%$
5. Operating temperature range:  $-40^\circ\text{C}$  to  $+200^\circ\text{C}$

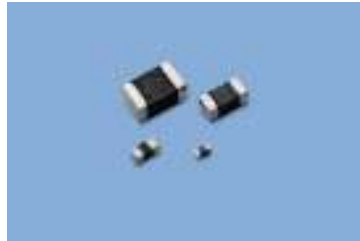

Fig.1 Appearance of TA thermistor series

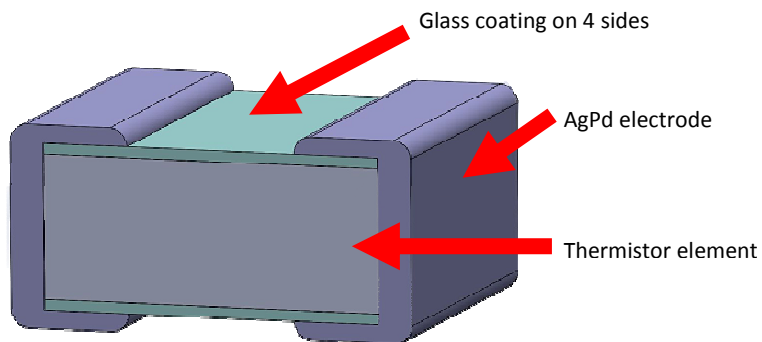

Fig.2 TA series cross-section

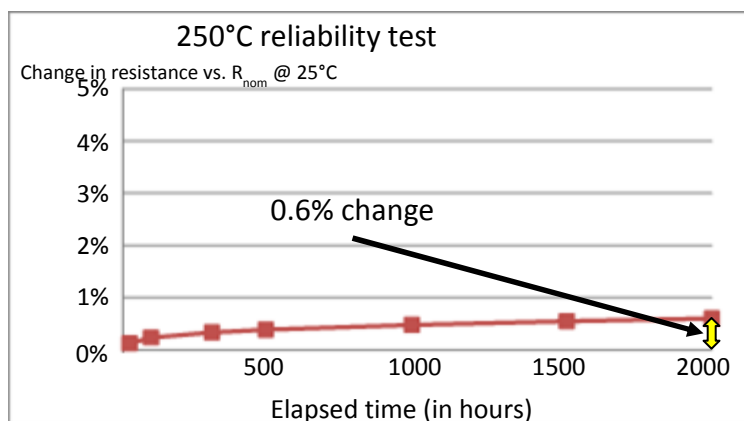

Fig.3 Resistance change after 2000 hour 250°C reliability test  
(Mean values obtained by measuring 20 samples per test)