



Application Note (1st Edition)

EMI Filter

**MITSUBISHI MATERIALS CORPORATION
ELECTRONIC COMPONENTS DIVISION**

Application Note (1st Edition)

Contents	Page
1. What is Noise	3
2. Countermeasures to Noise.....	4
1) Prevent Noise where there is an outbreak	
2) Stop Noise from being transmitted	
3) Applying Noise-counteracting parts at the place of interference	
3. Mitsubishi Materials EMI Filter Characteristics	7
1) 3 Terminal Filter	
2) 2 Terminal Filter	
4. Application Examples	11

1. What is Noise?

Large improvements in the efficiency and level of functionality in cell phones, computers and other telecommunications devices as well as image projection devices such as TVs and DVD players have made life more comfortable. However, with the miniaturization of electronics and increasingly high speed in transfer of data, electronic malfunction issues have increased as electromagnetic interference also increased. The solution is known as electromagnetic compatibility, or EMC.

There are two design requirements for electronic devices.

- 1) Countermeasures for electromagnetic interference (EMI) need to be implemented so that the device will not become a source of noise.
- 2) Countermeasures for electromagnetic susceptibility (EMS) need to be implemented so that the device will not be influenced by noise in the environment.

These two requirements are called electromagnetic compatibility, or EMC. EMC is the idea that emission problems and immunity, (resistance), problems coexist. In other words, if both noise produced from the device itself and noise penetrating externally are countered, noise problems can be resolved.

Every nation establishes policy for EMC standards. If electronic parts do not conform to a country's standards they cannot be sold in that market. For that reason, the design and development of electronic devices with EMI and EMS countermeasures are in strong demand.

Noise has the same electromagnetic energy as the electrical signal. This noise cannot be seen and penetrates through a variety of routes causing malfunction or deterioration in function of electronic devices.

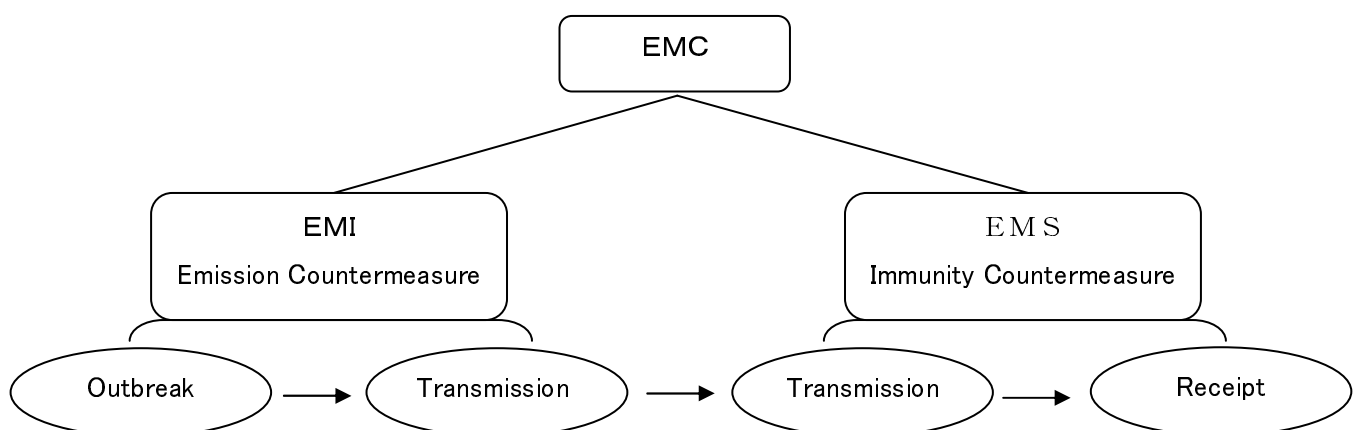

•Noise Penetration

There are two primary routes through which noise can penetrate. The first is through the cable via the printed circuit board signal or electrical source circuit pattern, which is known as transmission noise. The second enters from the air and is known as radiation or emission noise.

There are also cases when transmission noise travels through the air and changes into radiation noise.

Radiation noise can also change into transmission noise. The electromagnetic routes, which noise penetrates are made up of designs of set structures, such as components and wiring patterns. Together they become intertwined and complex.

2. Countermeasures to Noise

Noise can be controlled in three fundamental areas.

- 1) Outbreak Location
- 2) Transmission Area
- 3) Interference Location

Countermeasures can be implemented to prevent the noise from occurring at the outbreak location, stop noise from being transmitted, and by applying noise-cancelling parts at the place of interference.

1) Prevent noise from occurring at the outbreak location

Printed Circuit Board Design Countermeasure

① In below example number one, the printed circuit boards are constructed from the electricity source or signal layer, and the ground layer.

If an electric current flows between the electricity source/signal layer and the ground layer, a magnetic field will develop in the ends and become a cause of noise.

In example number two, if the symmetry between the electricity source/wiring and the printed circuit board changes, the magnetic field will come out of the ends and negate, making it more difficult for noise to occur. However, if the frequency of the wave is high as the symmetry deteriorates, the magnetic field will escape. At this point, the field connects with the magnetic field of the ground layer. The most common way to suppress this radiation noise is indicated in example three. Here, however, if the printed circuit board ground is not properly attached to the frame of the device with washers and screws, common mode noise will develop and the device will self destruct. Therefore, it is necessary to be extremely cautious on this point.

- ① Standard printed circuit board composition.

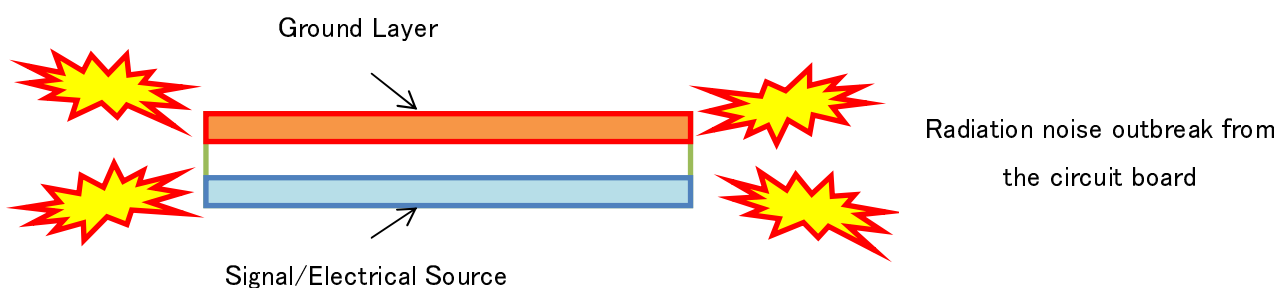

② Target change of the printed circuit board.

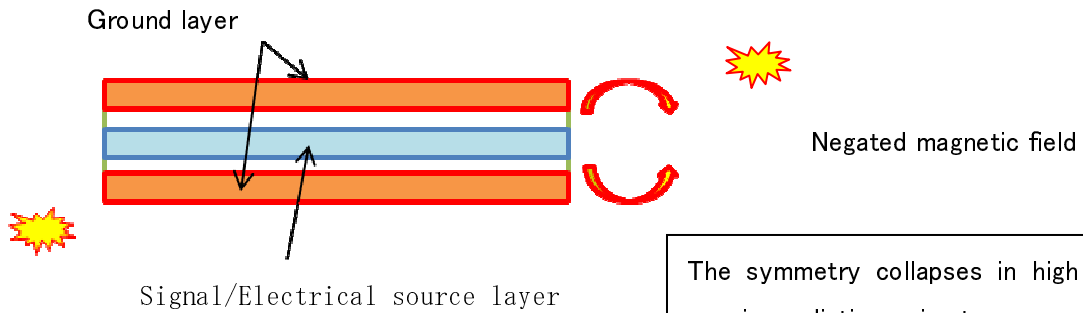

The symmetry collapses in high frequency causing radiation noise to occur.

③ Ground layer target change and connection of the magnetic fields.

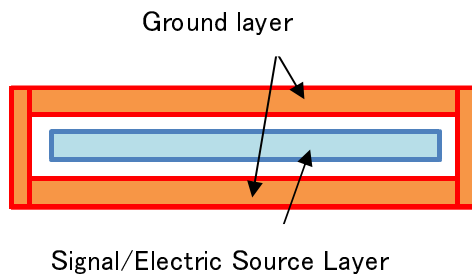

The outside electromagnetic field ceases to leak. However, to lower ground impedance, it is necessary to ensure the reliability of the connection to the ground.

2) Stop noise from being transmitted

Magnetism Shield

Noise is not just electrically transmitted, it can also travel through the air. However, to stop noise coming from magnetic force or lines of magnetic force, a shield must be applied. The magnetic shield is a new design where the side of the filter that receives noise will be surrounded completely by absorber film made from a metal case and magnetic materials. It is widely used in small efficient wireless equipment such as mobile phones, television and other audio-visual devices such as DVD players.

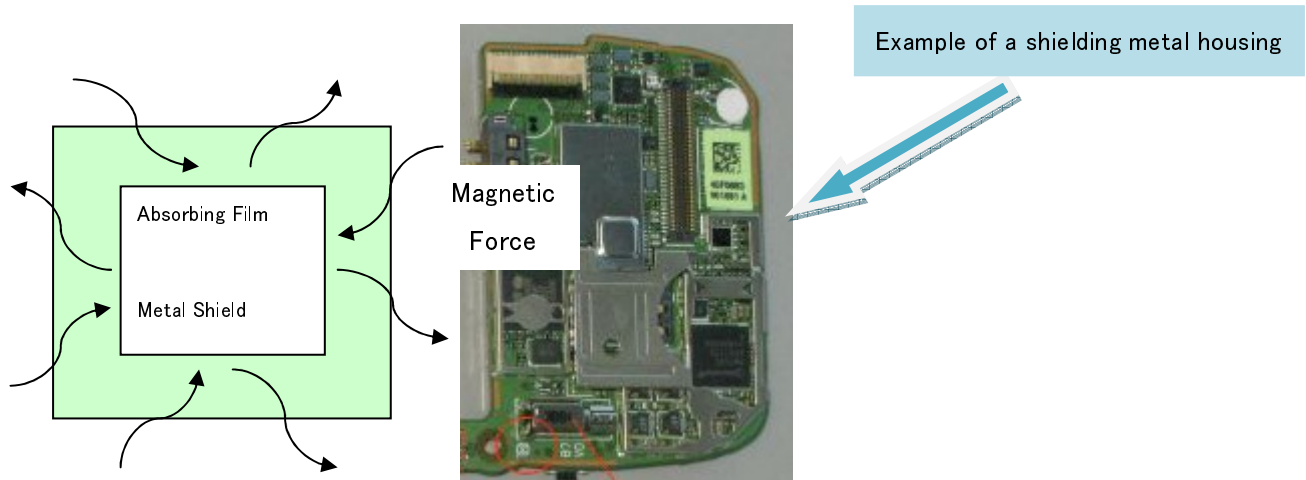

3)Applying noise-counteracting parts at the place of disturbance.

When noise confuses an incoming signal, the noise and signal can be separated or just the noise itself can be removed. Because noise usually occurs at a higher frequency zone, 3 terminal low-pass filters are commonly used. When choosing a filter it is necessary to verify that both the circuit board's in-out impedance and ground impedance are sufficiently shortened. If correctly chosen, the filter will allow the necessary signal to pass through the ground plain and dissipate into heat energy, making noise eradication possible. Still, when it comes to ground impedance and small unstable devices, cell phones or some circuit board patterns that cannot be altered, 2 terminal model noise counteracting parts, as in ferrite beads, are generally used. However, at our company we believe our LZA series LC filter to stands up better to difficult high resolution environments.

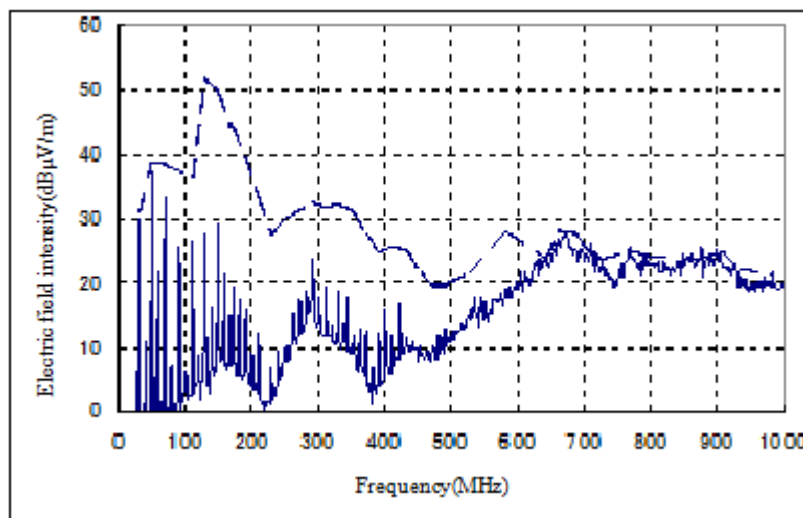

Signal Intensity with and without the Filter

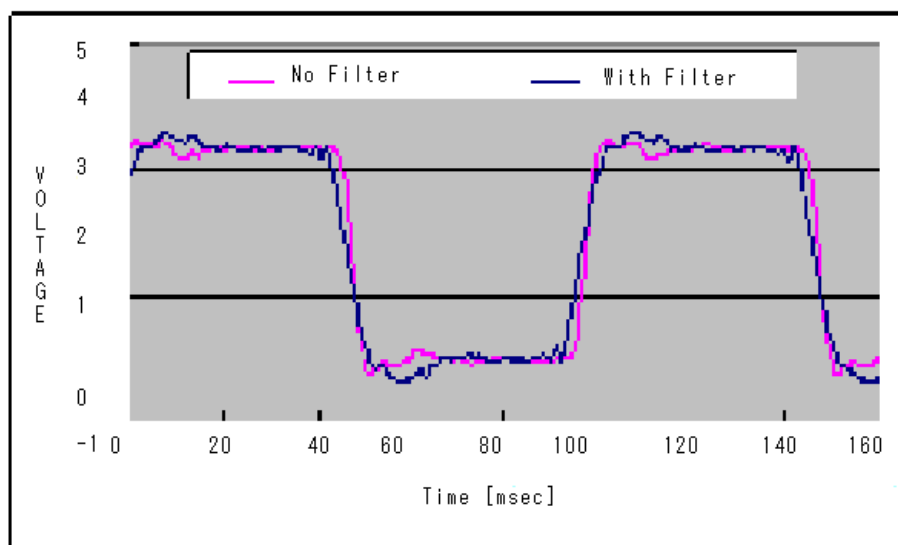

Signal Intensity with and without the Filter

3. Mitsubishi Materials EMI Filter Characteristics

1) 3 Terminal Filter

The 3 terminal LZA series LC filter is a high dielectric constant body part, (produced by combining and baking dielectric and magnetic composites), developed exclusively by our company. Our LC filter, (L for inductor and C for condenser), is a complex, high efficiency signal line filter.

Dielectric and magnetic substances are completely different materials and it took our company many years to develop the right ceramics materials and techniques to use the two freely. We have been successful in developing the ideal single dielectric magnetic material to create a filter with a steep interception range and wide insertion loss characteristics. In order to adopt the distribution constant in the equivalence circuit for the LC multilayer model, the filter does not warp the incoming wave, but successfully removes the noise only.

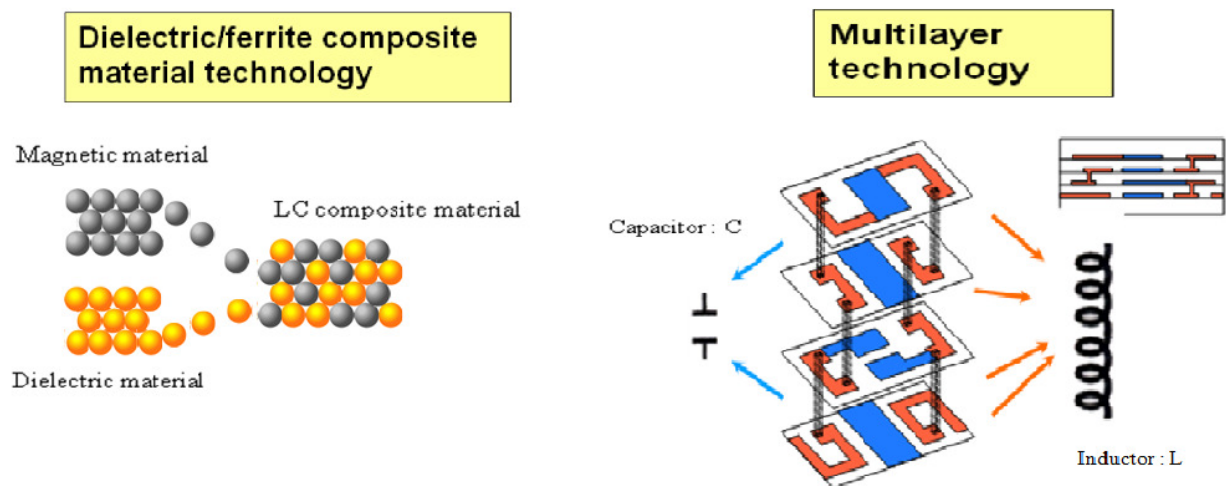

Graph of the LFA Series Specialty

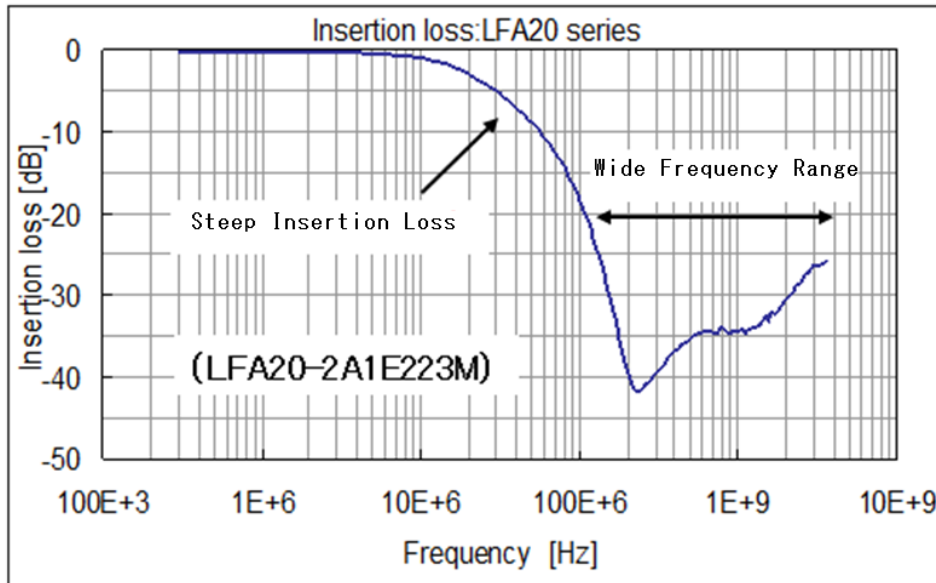

Example of LFA Insertion Loss Characteristics

Our filters can support a variety of manufactured goods. As signal frequencies have become higher, IC clocks and data base wave signals have become progressively faster. Our LCA and LCG filter series, with their ultra-steep interception range and wide insertion loss characteristics, can support even a case when the signal and the noise frequency are adjoined. The example below shows the similarity between the 100MHz LFA20-2A1E104M and the LCA20-2A1E104M in shape, cutoff and insertion loss characteristics. In comparison to the LFA20, the LCA has a faster, steeper close-zone cutoff frequency when removing noise. The most important theme in electronic device design has been to increase functionality while reducing power usage. In order to do this, the addition of on-board point DC/DC converters is unavoidable while an increase in noise countermeasures has become a necessity. Using the direct current electrical source, our company's 3 terminal LFB series filter is effective in reducing DC/DC converter switching noise. At its 3.2x1.6~1.0x.05mm optimum size, this filter is the most practical choice when consideration space on a circuit board.

LFA20 and LCA20 Insertion Loss Comparison

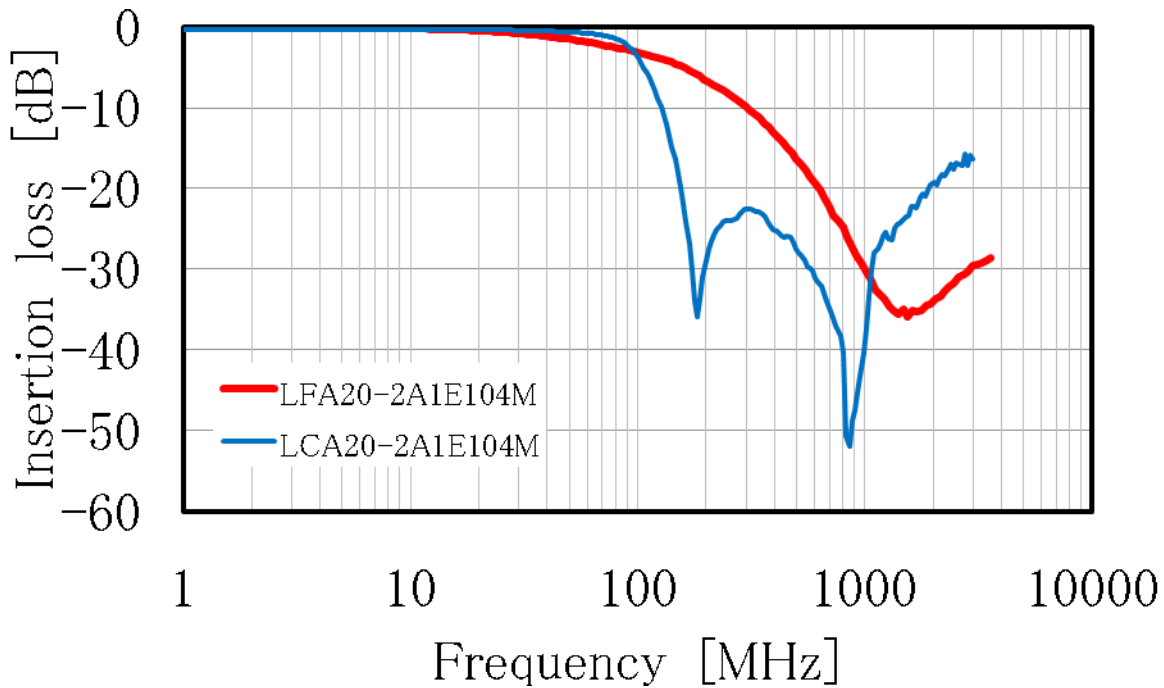

Recommended Filters

Part Number	Size (mm)	Cut Off Frequency (KHz)	Current (A)	Voltage (V)
LFB05-3D1A561M	1.0 × 0.5	560	2	10
LFB10-3D1E561M	1.6 × 0.8	560	2	25
LFB20-3D1E471M	2.0 × 1.25	470	2	25
LFB30-3D1E471M	3.2 × 1.6	470	2	25



2)2 Terminal Filter

The 2 terminal LZA and LFA series LC filters have similar characteristic materials made from a high dielectric magnetic substance. The illustration below points out the filters’ particular band stop model characteristics. The outside appearance and size are identical to ferrite beads, making replacement and loading easy. In the same circuit, however, they will perform differently because LZA will have inductor and capacitor characteristics. The LZA series is especially effective in removing noise that has adjoined with the signal without compromising the integrity of the signal. The following gives an example of the LZA’s noise removal effectiveness. When noise needs to be removed at 100MHz, the small constant ferrite beads (120 Ohms) become ineffective. For this, large constant ferrite beads (1000 Ohms) can remove noise, but in doing so, the loss zone widens and the quality of the signal cannot be maintained. Large signal distortion becomes a problem. These problems caused by ferrite beads have been easily resolved with the

implementation of our LZA series filters. As shown in the example below, by using the LZA10-2ACB104M filter with a fast, steep resonance point at 100MHz, the signal is relatively undistorted while just the noise is removed.

The LZA series filter composed of dielectric and magnetic materials that can all be controlled. Whether the application is for an equivalence circuit the decay frequency, zone, or attenuate quantity, the characteristics can be changed on demand for optimum results. Utilizing a 3 terminal filter can remedy many problems in which the only other solution is time consuming, costly and troublesome design changes.

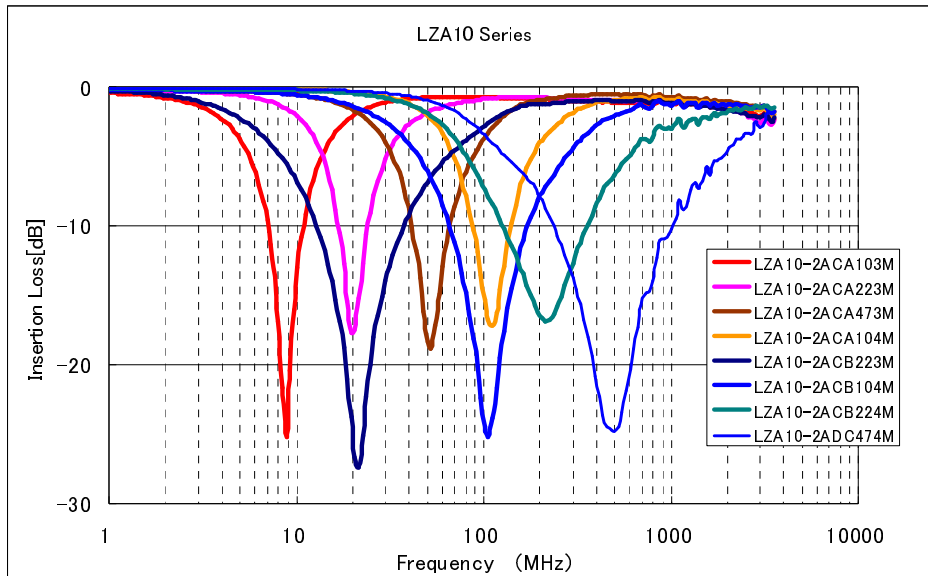

LZA Series Insertion Characteristics Examples

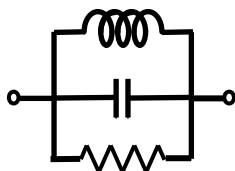

LZA Series Typical Circuit

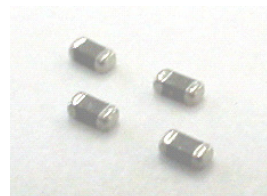

LZA Series Picture

Comparison of LZA Series to Ferrite Beads

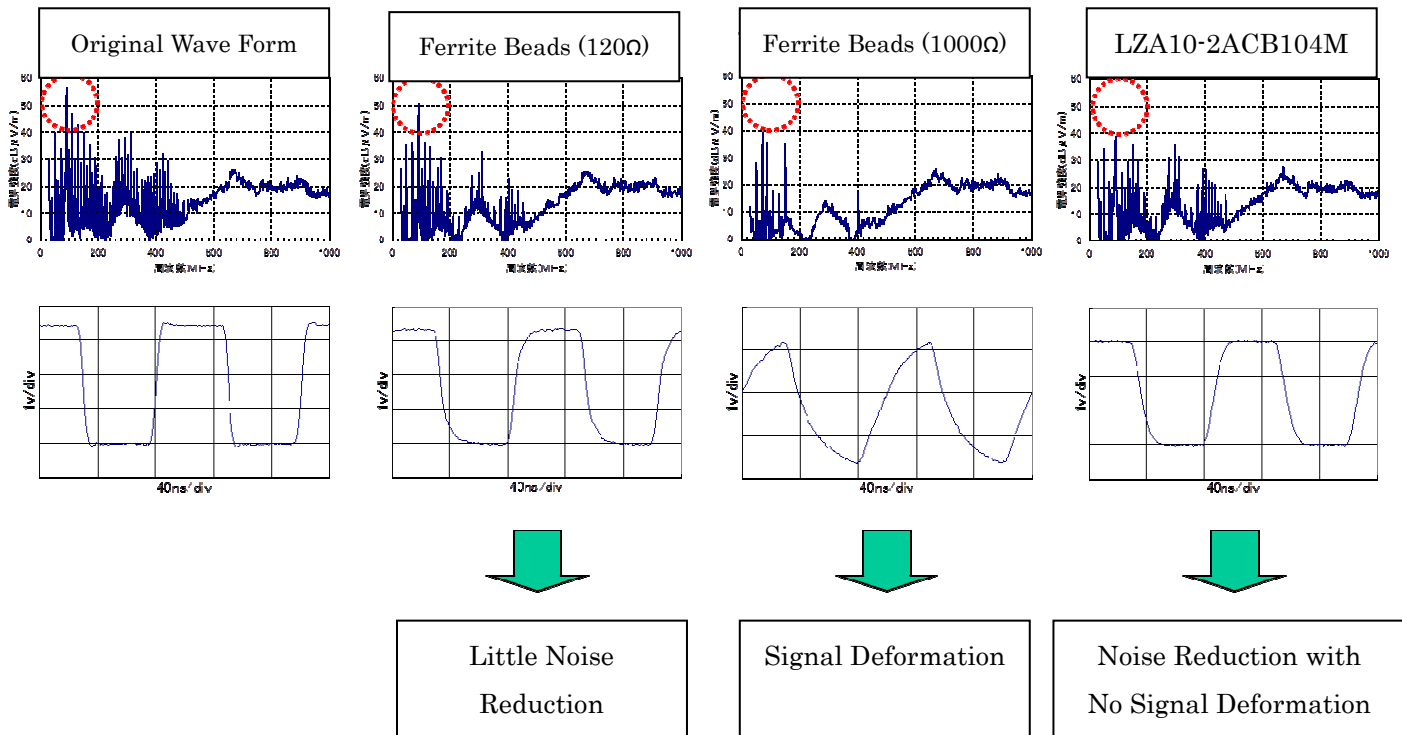

4. Examples Showing Use

■ Clock Line Noise Countermeasure

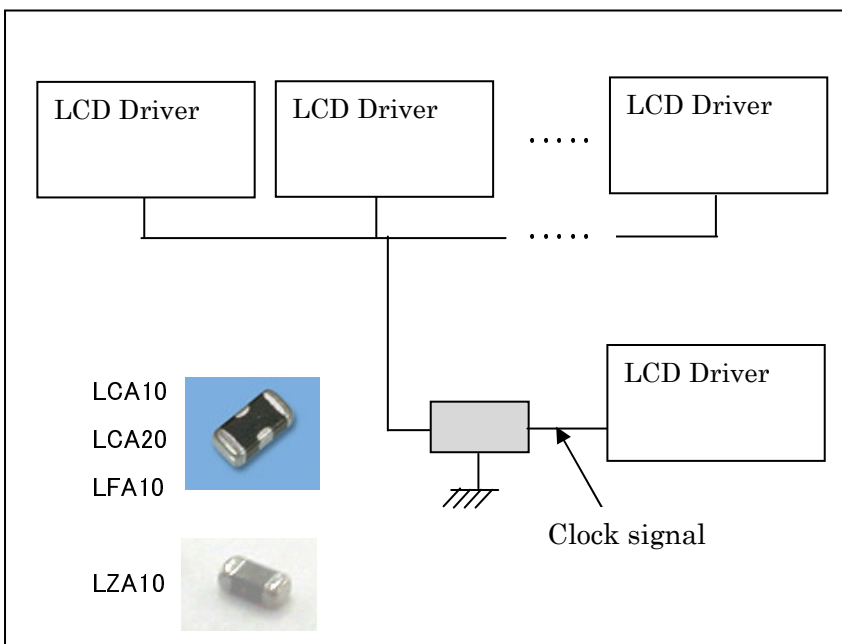

Mobile phone, LCD panel, Digital Equipment

Optimum performance when the clock signal frequencies are adjoined.

■ Data Line Noise Countermeasure

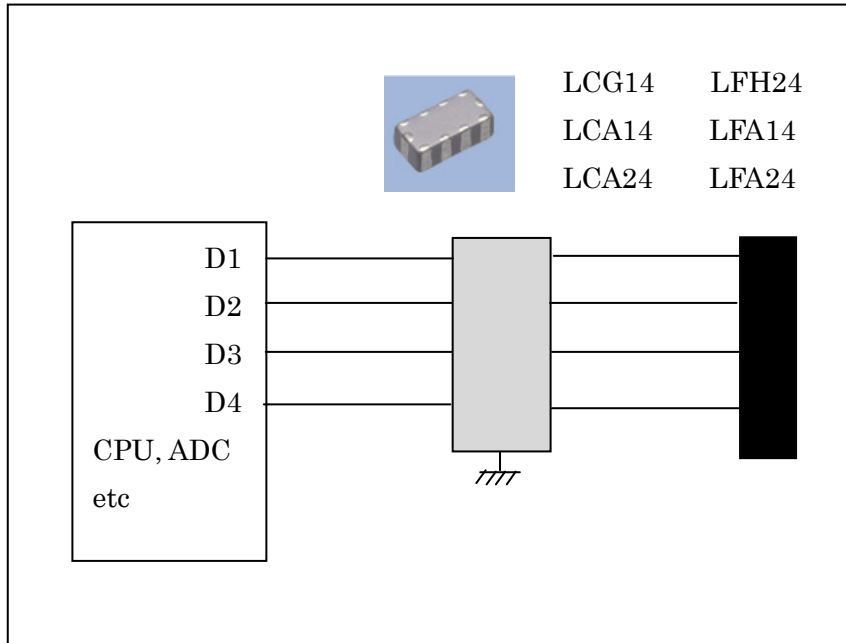

Mobile phone, Copier, LCD panel, Digital Equipment
 Optimum performance when the signal frequencies are adjoined.

■ Powerline Noise Countermeasure

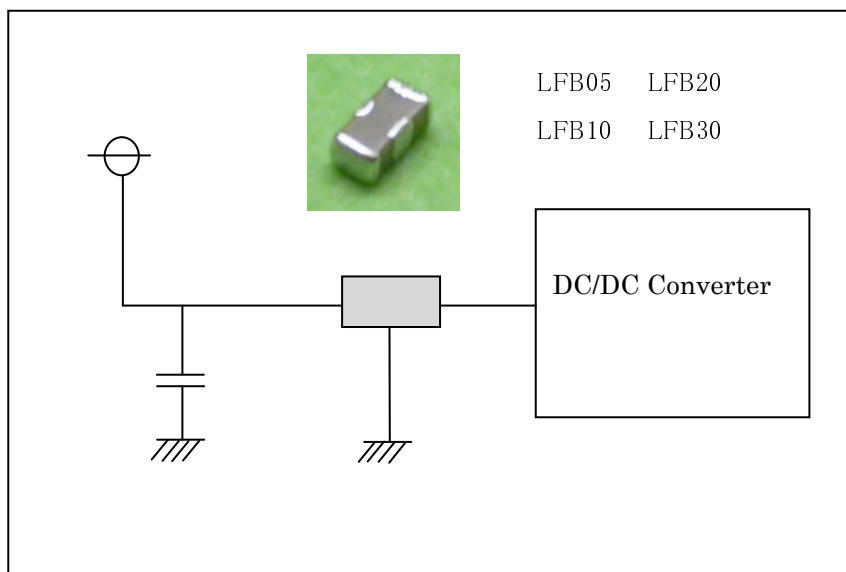

Mobile Phone, MPEG, PND, Digital Equipment
 Optimum Space for Circuit Boards