

■混响测试装置(BLUETEST公司制造)

混响室可在极短的时间内完成可在 W-CDMA、GSM、LTE、Bluetooth、W-LAN等多路径环境中动作的小型天线的放射效率测量。

可替代以往根据电波暗室中三次元放射模式数据的积分进行评估的小型天线评估法。

最适合用于在头部模型近旁的通话位置进行终端测量，评估人体的影响。

■Reverberation Test System(BLUETEST AB)

The reverberation chamber make it possible to measure in a short time radiation efficiency of small antennas for multi-path environment such as W-CDMA, GSM, LTE, Bluetooth and W-LAN.

This test system is an alternative to conventional evaluation method of integration of the three-dimensional radiation pattern data measured in the anechoic chamber.

The system is particularly suitable to measure terminals in the immediate vicinity of a head phantom in order to evaluate human body effects.

测定项目 Supported Measurements	天线放射效率 Antenna Efficiency Measurements
	分集 Passive Diversity
	复合天线相关系数 Passive Multi-Input Multi-Output (MIMO)
测定频率范围 Frequency Range	650MHz~6GHz
射频屏蔽 RF Shielding	> 100dB
测定偏差 Accuracy	0.3 dB (STD)
再现性 Repeatability	0.1 dB (STD)
测定时间(典型) Test Time (Typical)	天线放射效率 1分钟 Passive Antenna Measurements 1 min
	分集增益 1分钟 Passive Diversity Gain 1 min
	MIMO容量 1分钟 Passive MIMO Capacity 1 min

模拟人体模型(头部) Head Phantom

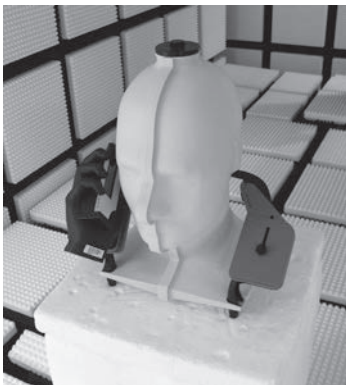

混响室 Reverberation chamber



■联系方式 Inquiry

菱庆材料(上海)贸易有限公司
MMC SHANGHAI CO., LTD.

中国上海市长宁区古北路678号同进大厦12B01室
邮政编码: 200336
Room 12B01, Winners Building
678, Gubei Road,
Shanghai, 200336 China
TEL: +86-21-6247-2951 FAX: +86-21-6247-2945
E-mail: ml-mmcshsl@mmc.co.jp

CHINA HONG KONG

MMC ELECTRONICS (HK) LTD.
17/F., Westley Square 48 Hoi Yuen Road, Kwun Tong, Kowloon, Hong Kong
E-mail: ml-mmehsale@mmc.co.jp
TEL.+852-2-305-4296 FAX.+852-2-759-7536

■蜂窝宽带有源 (OTA) 测试评估

通过混响室+通讯测试器 (安立公司生产的MT8821C) 的测试系统可评估OTA。

基于以各种通讯方式进行RF通讯收发测试的3GPP (3rd Generation Partnership Project)。

最新的通讯方式: 应对载波聚合 ⇒ 可测试2CA/2x2 MIMO。

■The active (OTA) test for celler band

※OTA:Over the Air

By a combination of Reverberation chamber and Communication tester, the OTA measurement is possible fast.

It is based on the RF transmit and receive test of various communication methods for 3GPP.

The latest communication method:Carrier Aggregation ⇒2CA / 2x2 MIMO is available.

测试项目 Supported Measurements	TRP (总辐射功率) Total Radiated Power
	TIS (总灵敏度各向同性) Total Isotropic Sensitivity
通讯方式 Communication System	符合3GPP test specification TS 34.114。 Conformed to 3GPP test specification TS 34.114 <ul style="list-style-type: none"> •LTE FDD / LTE-Advanced •LTE TDD / LTE-Advanced •GSM / GPRS / EGPRS •W-CDMA / HSPA+ •TD-SCDMA / HSPA •2x2 SIMO / MIMO
测量时间 (公称) Test Time (Typical)	TRP测试 5分钟/channel TRP Measurements 5 min./channel
	TRP测试 15分钟/channel TIS Measurements 15 min./channel

测试系统 Measurement System

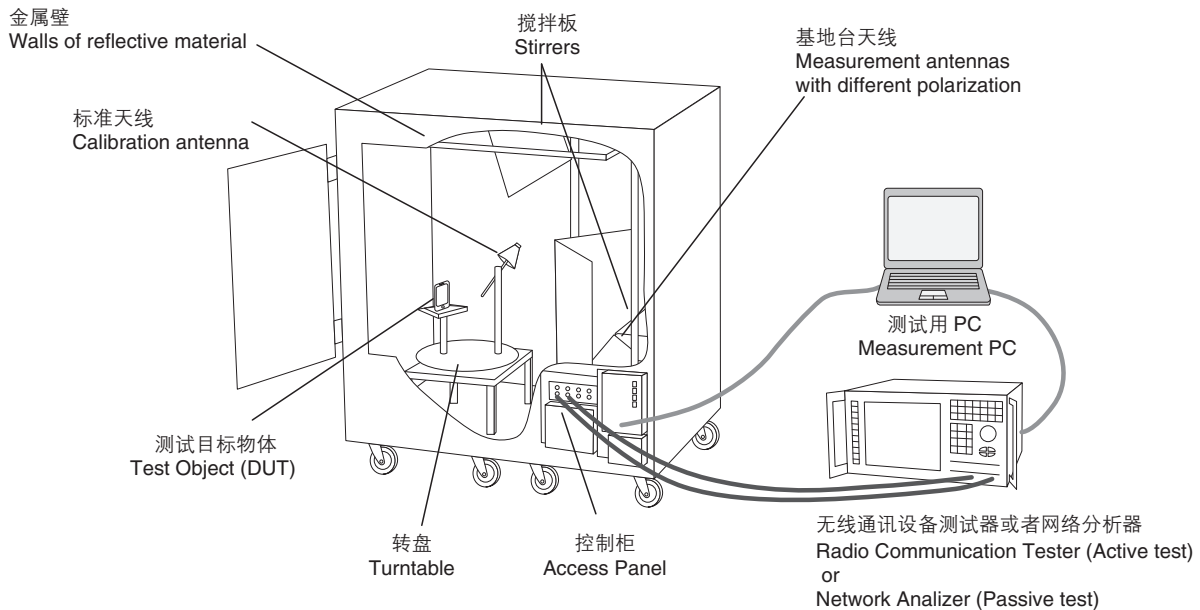

贴片天线
CHIP ANTENNAS

三菱材料为客户的天线设计提供解决方案。

本公司采用电波暗室实施测试，可快速地应对客户需求。

通过三次元（球面）测量系统，可全面测量以智能手机、功能手机、LTE装置为代表的放射性效率。
致力于不断地丰富充实天线技术。

We are pleased to offer customers antenna design solutions.

We utilize anechoic chamber so that we can respond promptly to requests from customers.

We can measure radiation characteristic of smart-phones, feature-phones, LTE Devices from all-round views with three-dimensional measurement system. We always try to upgrade our antenna technical support for customer satisfaction.

结构 Structure	内壁6面由2层铁氧体瓦块+泡沫苯乙烯电波吸收体构成 Inner wall 6 surfaces of 2 layer ferrite tile + styrene foam absorber	
尺寸 Size	3m法电波暗室 3 Meter Anechoic Chamber	
	室内尺寸: 6.1m(W)x3.1m(D)x2.5m(高) Interior dimensions: 6.1m (W) x3.1m (D) x2.5m (H)	
	屏蔽面尺寸: 7.0m(W)x4.0m(D)x3.0m(高) Shield surface size: 7.0m (W) x4.0m (D) x3.0m (H)	
电气性能 Electric efficiency	安静区 Quiet zone	φ 50cm(球形)、中心高度1.05m φ 50cm (spherical), center height 1.05m
	天线测定 Antenna measurement	300MHz~18GHz
	EMI测定 EMI measurement	30MHz~1GHz
	电磁屏蔽特性 Electromagnetic shield characteristics	150kHz~18GHz
	电源线屏蔽特性 Power source line characteristics	150kHz~18GHz
附带设备 Supplement equipment	天线定位器 Antenna positioner	
	转盘 Turntable	
	ITV系统 ITV system	
	三次元(球面)测定系统(二次元→三次元测定切换可) three-dimensional measurement system (Switch to three-dimensional measurement)	
测量机器 Measurement equipment	天线 Antenna	偶极、双锥、对数周期、喇叭 Dipole, Bi-conical, log periodic, horn
	信号发生器 Signal generator	
	频谱分析器 Spectrum analyzer	
	网络分析器 Network analyzer	

电波暗室
Anechoic Chamber

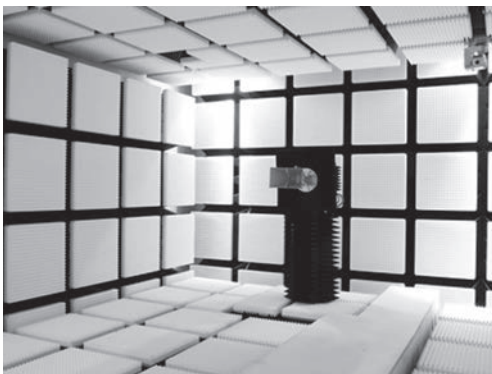

三次元(球面)测定系统
three-dimensional measurement system

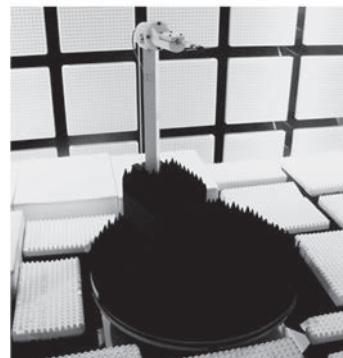

表面实装型贴片天线

SURFACE MOUNTABLE CHIP ANTENNA

表面贴装电介质贴片天线是结合了应用广泛的本公司高频陶瓷技术与最先进高频设计技术的高性能透电式天线。具有小型、薄型、频带宽的特性。适合配置于小型便携式设备及通信模块中。

贴片天线

AM11DP-ST01 * :400 ~ 1600MHz
AM03DP-ST01 * :1500 ~ 6000MHz

■特点

- 小型、薄型天线
- 高收益
- 无指向性
- 通过外部调整电路，可容易地调整至适用频带

天线单元 (开发产品)

UB14CP-00ST01
UB18CP-00ST01
UB23CP-00ST01

■特点

- 小型
- 是安装了贴片天线、匹配电路、同轴连接器的天线单元
- 无需进行电路板设计，减少了开发费用和最初成本

Surface mountable dielectric chip antennas are result of harmonizing our long experience in ceramic material & process technologies for high frequency applications together with cutting-edge RF design technologies. It is very small with low profile, but has a wide range of frequency band. It is suitable for compact mobile equipment and communication modules.

CHIP ANTENNA

AM11DP-ST01 * :400 ~ 1600MHz
AM03DP-ST01 * :1500 ~ 6000MHz

■Features

- Very small
- High gain
- Omini-directional
- With an external tuning circuit, the adjustment to an application frequency range is possible.







ANTENNAUNIT (Development)

UB14CP-00ST01
UB18CP-00ST01
UB23CP-00ST01

■Features

- very small
- The antenna unit has a chip antenna with a matching circuit and a coaxial cable.
- Full turnkey solution can save time, design and initial cost.

■产品介绍 Products line up

产品 Products	型号 Parts number	形状 Style	频率范围 Frequency range	用途 Applications	尺寸 Size	页码 Page	备注 Notes
贴片天线 Chip antenna	AM11DP-ST01 *		利用外部调整电路，可在400~1600MHz的范围内改变适用频带 With an external tuning circuit, frequency range is applicable from 400~1600MHz.	智能电表 Smart meter HEMS, BEMS 安全 Security 遥测仪 Telemeter 无钥匙进入 Keyless entry GPS	10.5×3.0×0.8mm	95~97	—
	AM03DP-ST01 *		利用外部调整电路，可在1500~6000MHz的范围内改变适用频带 With an external tuning circuit, frequency range is applicable from 1500~6000MHz.	Bluetooth 无线LAN Wireless LAN ZigBee PHS DECT	3.2×1.5×0.5(MAX)mm	98	—
	AW03DP-245ST01 *		2GHz:2400~2484MHz 5GHz:4900~5900MHz	无线LAN Wireless LAN		99	—
开发产品 Development 天线单元 Antenna Unit	UB14CP-100ST01		910~920MHz	智能电表 HEMS, BEMS 安全设备 遥测仪 电机发动器 GPS	50.0×10.0×0.8mm	100	·利用外部调整电路，可在400~1600MHz的范围内改变适用频带 With a tuning circuit, frequency range is applicable from 400~1600MHz.
	UB18CP-100ST01		2400~2484MHz	Bluetooth 无线LAN Wireless LAN ZigBee	30.0×5.0×0.8mm	101	·利用外部调整电路，可在1500~2500MHz的范围内改变适用频带 With a tuning circuit, frequency range is applicable from 1500~2500MHz.
	UB23CP-100ST01		2GHz:2400~2484MHz 5GHz:5150~5730MHz	无线LAN Wireless LAN	40.0×10.0×0.8mm	102	—

※ "*" 包含了包装符号 (T : 密封 或 B : 散装)

"*" means packing code. T : Taping B : Bulk pack

用于 920MHz (915MHz) 带 For 920MHz(915MHz) Band

● AM11DP-ST01 *



■特点

- 小型、薄型天线
- 高增益
- 全向性
- 利用外部调整电路，可调节适用频段
频率范围：400MHz~1600 MHz

■用途

- 智能电表、有源标签等

■Features

- Very small
- High gain
- Omini-directional
- With an external tuning circuit, the adjustment to an application frequency range is possible.
Frequency range:400 MHz:1600 MHz.

■Applications

- Smart Meter, Active Tag, etc

■形状・尺寸 Dimensions

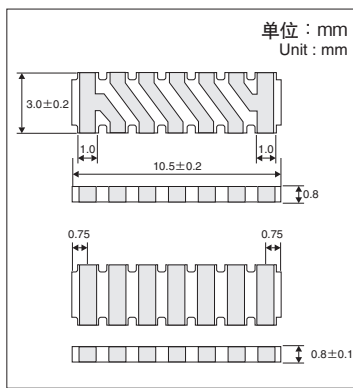

■ V.S.W.R. 的特性及其放射特性 (参考)

V.S.W.R. & radiation characteristics (Reference) :

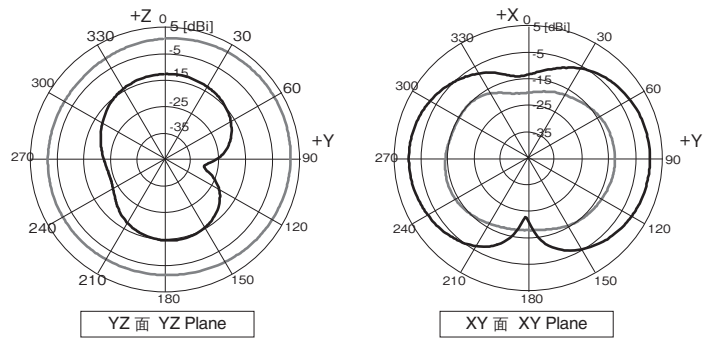
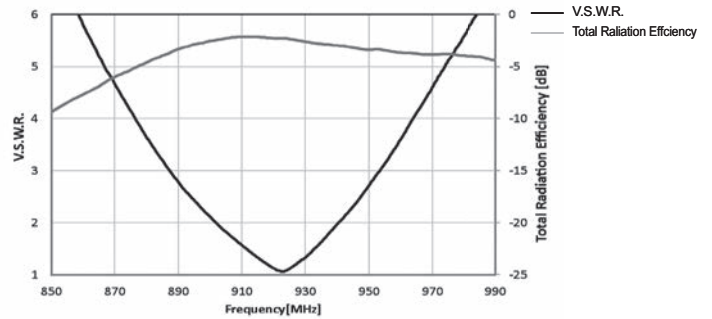

< 频带宽度 Band width >
V.S.W.R. ≤ 3 : 65MHz
< 增益 Gain @920MHz >
平均 Average: -1.8dBi
最大 Maximum: +1.7dBi

— 水平偏振
— 垂直偏振

* 上述特性为典型特性，并非保证特性。
* These characteristics are not guaranteed ones, but typical ones.

※本公司试验电路板调整实例 (Ex) 915MHz

fc [MHz]	电感 [nH]		
915	L1	L2	L3
	8.7	39	7.5

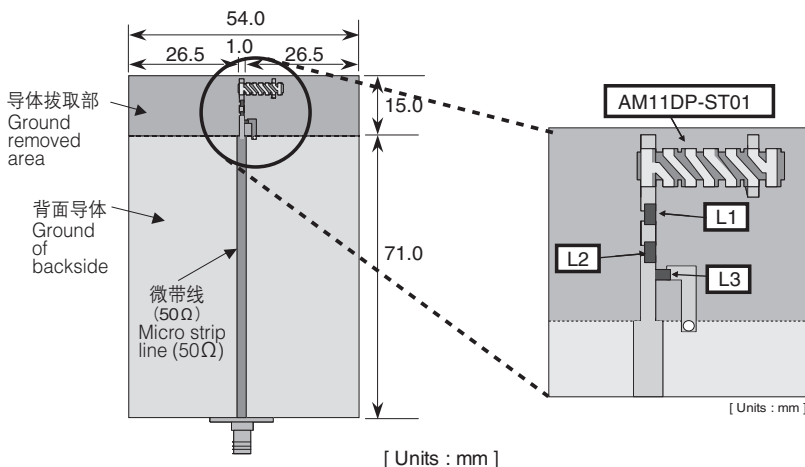
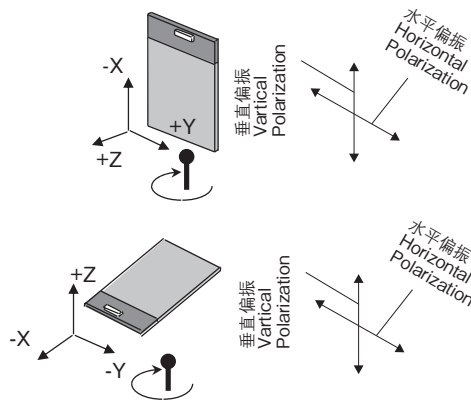

用于 868MHz 带 For 868MHz Band

● AM11DP-ST01 *



■特点

- 小型、薄型天线
- 高增益
- 全向性
- 利用外部调整电路，可调节适用频段
频率范围：400MHz~1600 MHz

■用途

- 销往欧洲的无线设备

■Features

- Very small
- High gain
- Omni-directional
- With an external tuning circuit, the adjustment to an application frequency range is possible.
Frequency range:400 MHz:1600 MHz.

■Applications

- Wireless equipment for Europe, etc

■形状・尺寸 Dimensions

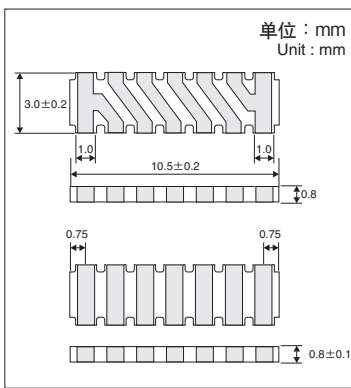

■ V.S.W.R. 的特性及其放射特性 (参考)

V.S.W.R. & radiation characteristics (Reference) :

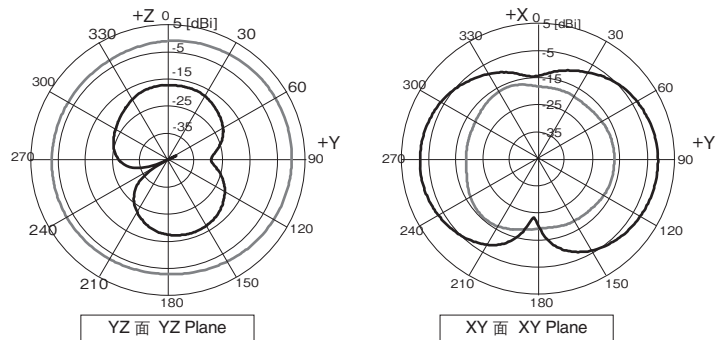
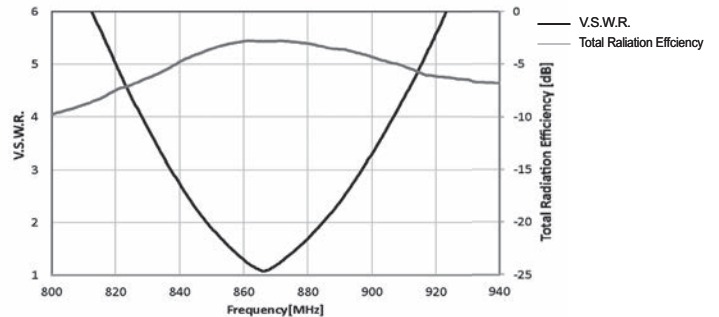

< 频带宽度 Band width >
V.S.W.R. ≤ 3 : 57MHz
< 增益 Gain @868MHz >
平均 Average: -3.2dBi
最大 Maximum: 0dBi

— 水平偏振
— 垂直偏振

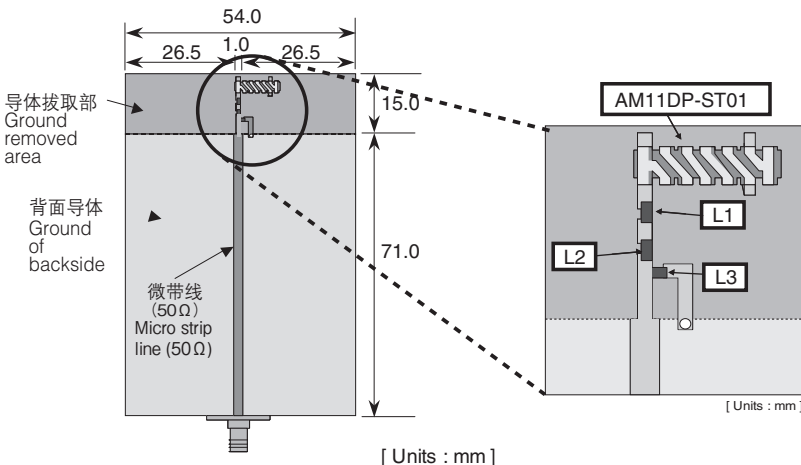
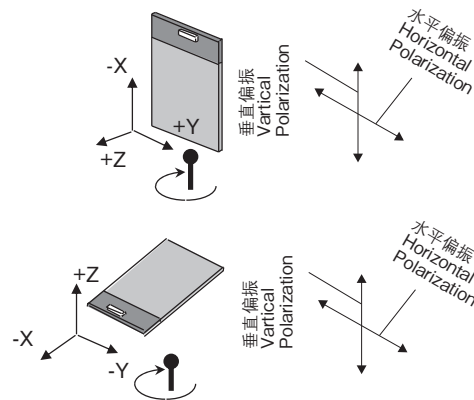

* 上述特性为典型特性，并非保证特性。
* These characteristics are not guaranteed ones, but typical ones.

※本公司试验电路板调整实例 (Ex) 868MHz

fc [MHz]	电感 [nH]		
868	L1	L2	L3
	4.3	47	8.2

用于 430MHz 带 For 430MHz Band

● AM11DP-ST01 *



■特点

- 小型、薄型天线
- 高增益
- 全向性
- 利用外部调整电路，可调节适用频段
频率范围：400MHz~1600 MHz

■用途

- 遥测仪、遥控器、数据通信

■Features

- Very small
- High gain
- Omini-directional
- With an external tuning circuit, the adjustment to an application frequency range is possible.
Frequency range:400 MHz:1600 MHz.

■Applications

- Telemeter,
Telecontroller, Data communication,etc

■形状・尺寸 Dimensions

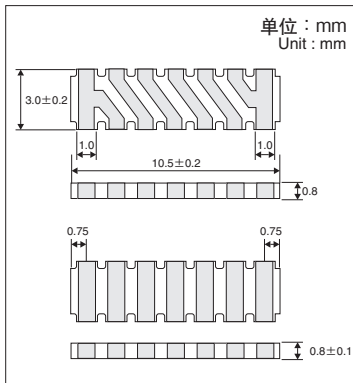

■ V.S.W.R. 的特性及其放射特性 (参考)

V.S.W.R. & radiation characteristics (Reference) :

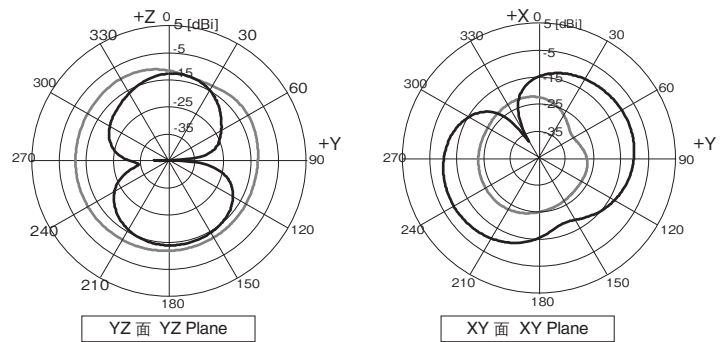
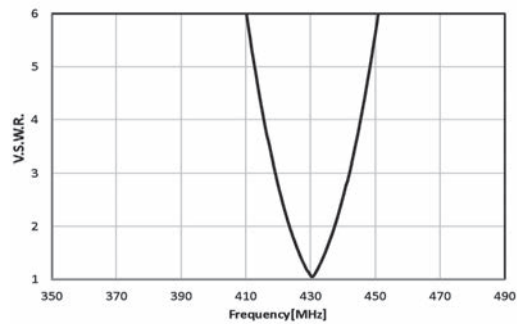

< 频带宽度 Band width >
V.S.W.R. ≤ 3 : 16MHz
< 收益 Gain @430MHz >
平均 Average: -11.0dBi
最大 Maximum: -8.7dBi

— 水平偏振
— 垂直偏振

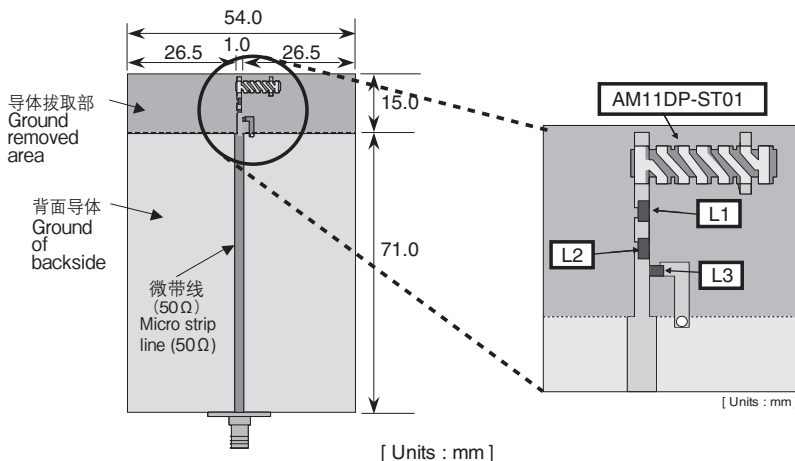
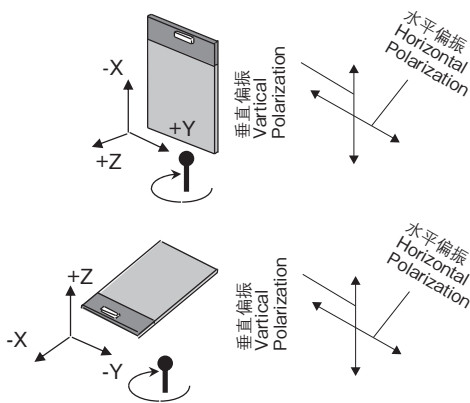

* 上述特性为典型特性，并非保证特性。
* These characteristics are not guaranteed ones, but typical ones.

※本公司试验电路板调整实例 (Ex) 430MHz

fc [MHz]	电感 [nH]		
430	L1	L2	L3
	30	220	16

用于 2.4GHz 带 For 2.4GHz Band

● AM03DP-ST01 *

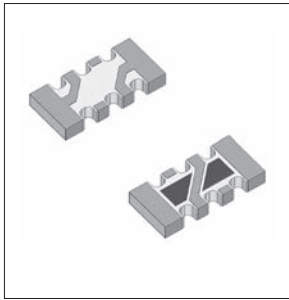

■特点

- 小型、薄型天线
- 高增益
- 全向性
- 通过外部调节电路，可容易地调节到各设备

■用途

- 无线 LAN、Bluetooth™ 等
- DECT (1.9GHz)

■Features

- Very small
- High gain
- Omni-directional
- With an external tuning circuit, the adjustment to an application frequency range is possible.

■Applications

- Wireless LAN, Bluetooth™ etc.
- DECT(1.9GHz)

■形状・尺寸 Dimensions

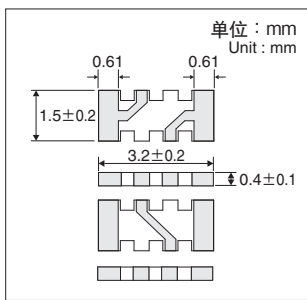

■ V.S.W.R. 的特性及其放射特性 (参考)

V.S.W.R. & radiation characteristics (Reference) :

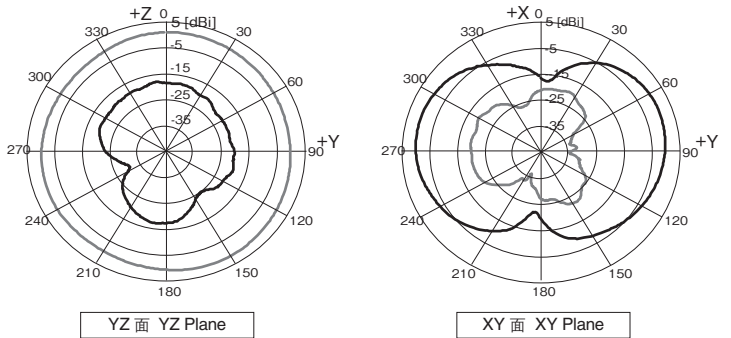
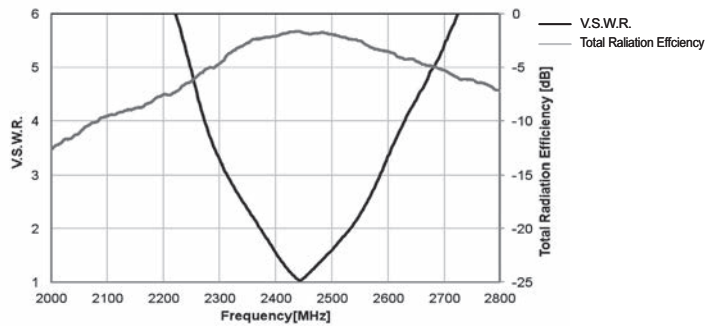

< 频带宽度 Band width >
V.S.W.R. ≤ 3 : 288MHz
< 增益 Gain @2442MHz >
平均 Average: -1.7dBi
最大 Maximum: +1.6dBi

— 水平偏振
— 垂直偏振

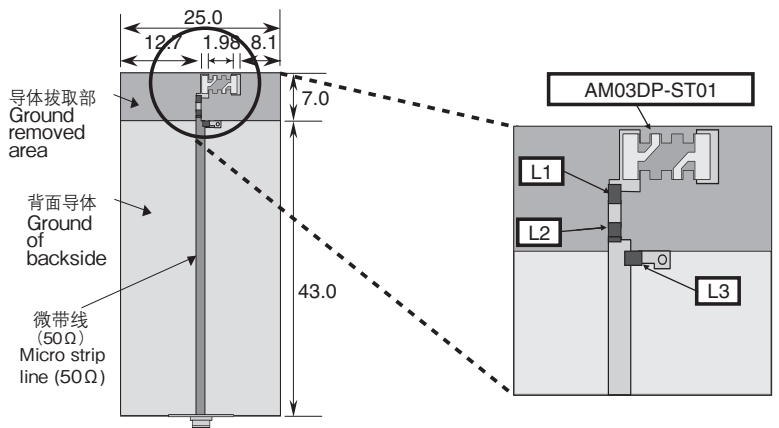
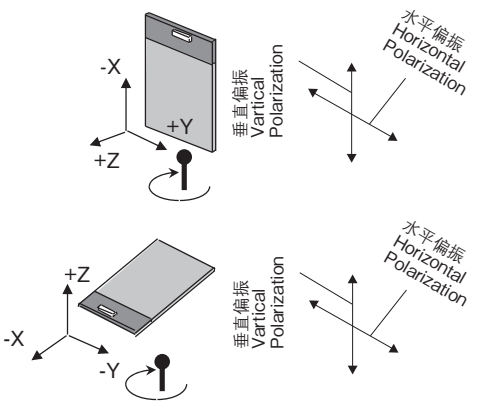

[Units : mm]

* 上述特性为典型特性，并非保证特性。
* These characteristics are not guaranteed ones, but typical ones.

※本公司试验电路板调整实例 (Ex) 2442MHz

fc [MHz]	电感 [nH]		
2442	L1	L2	L3
	2.9	8.7	2.4

用于 2.4&5GHz 带 For 2.4&5GHz Band

● AW03DP-245ST01 *

※变更为 AM03DP-ST01 的焊盘布局时，可对应双频天线。
AM03DP-ST01 can support a dual band antenna by changing the land pattern.

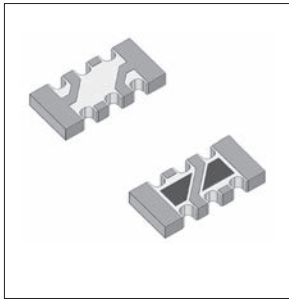

■特点

- 小型、薄型天线
- 高增益
- 全向性
- 通过外部调节电路，可容易地调节到各设备

■用途

- 无线 LAN

■Features

- Very small
- High gain
- Omini-directional
- With an external tuning circuit, the adjustment to an application frequency range is possible.

■Applications

- Wireless LAN

■形状・尺寸 Dimensions

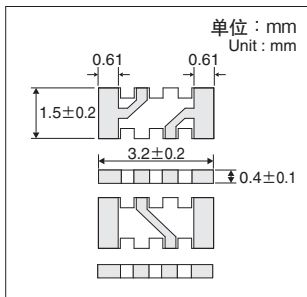

■ V.S.W.R. 的特性及其放射特性 (参考)

V.S.W.R. & radiation characteristics (Reference) :

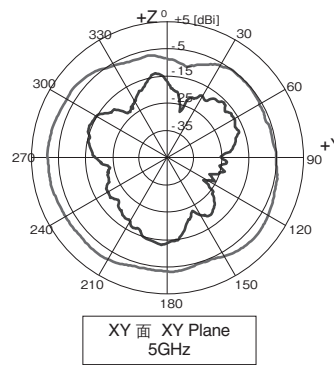
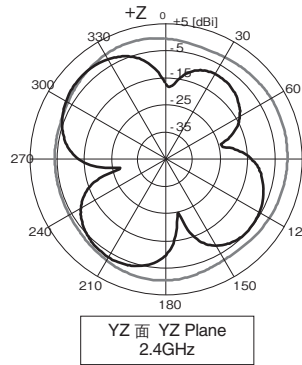
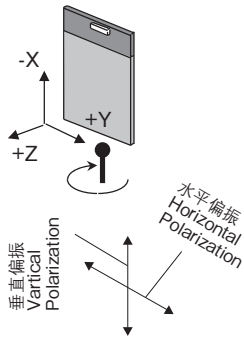
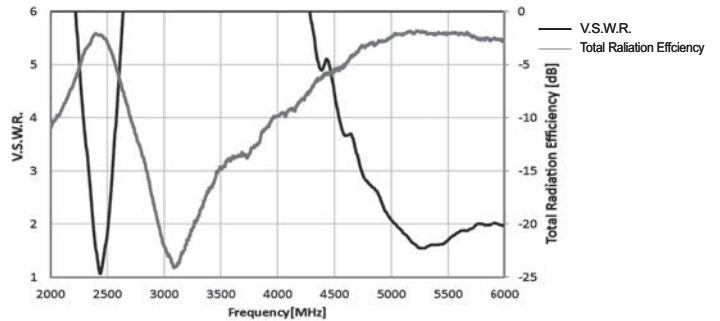

< 频带宽度 Band width >
@2.4GHz Band
V.S.W.R. ≤ 3 : 195MHz
@5GHz Band
V.S.W.R. ≤ 3 : 1477MHz

< 增益 Gain >
@2442MHz
平均 Average : -2.6dBi
最大 Maximum : +1.6dBi
@5200MHz
平均 Average : -3.1dBi
最大 Maximum : +2.1dBi

— 水平偏波
— 垂直偏波

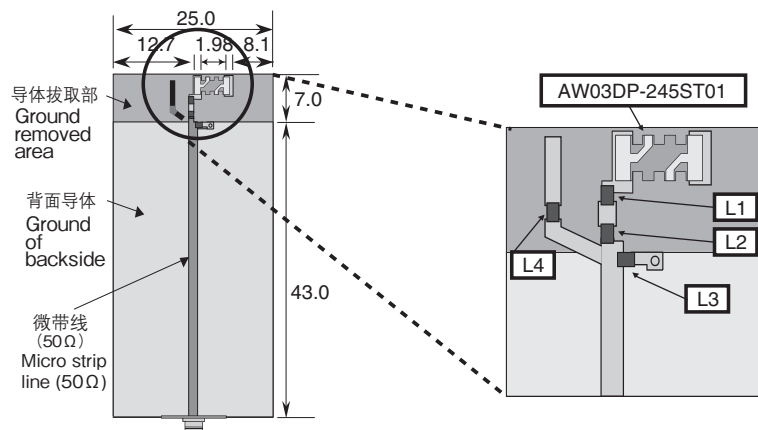

[Units : mm]

* 上述特性为典型特性，并非保证特性。
* These characteristics are not guaranteed ones, but typical ones.

※本公司试验电路板调整实例 (Ex) 2442MHz

fc [MHz]	电感 [nH]			
2.4&5 GHz	L1	L2	L3	L4
	2.4	8.2	2.5	2.4

用于 920MHz (915MHz) 带 For 920MHz(915MHz) Band

● UB14CP-100ST01

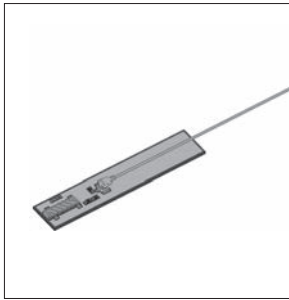

■特点

- 是安装了贴片天线、匹配电路、同轴连接器的天线单元
- 无需进行电路板设计，减少了开发费用和最初成本

■用途

- 智能电表、有源标签等

■Features

- The antenna unit has a chip antenna with a matching circuit and a coaxial cable.
- Full turnkey solution can save time, design and initial cost.

■Applications

- Smart Meter, Active Tag, etc

■形状・尺寸 Dimensions

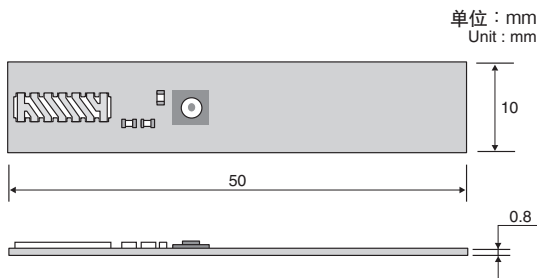

■ V.S.W.R. 的特性及其放射特性 (参考)

V.S.W.R. & radiation characteristics (Reference) :

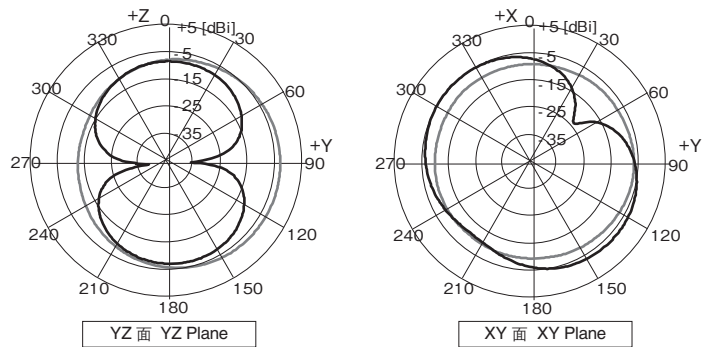
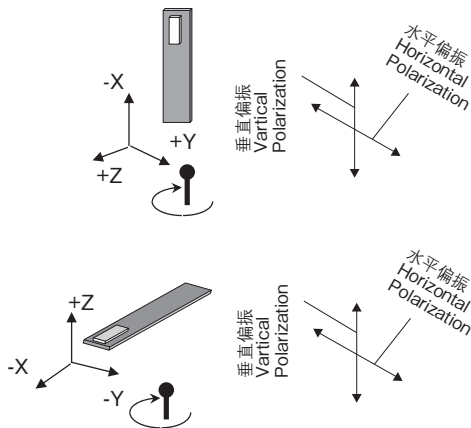
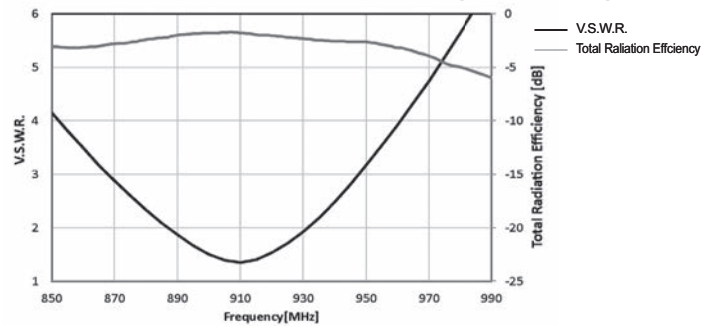

< 频带宽度 Band width >
V.S.W.R. ≤ 3 : 75MHz
< 增益 Gain @920MHz >
平均 Average : -4.2dBi
最大 Maximum : -1.8dBi

— 水平偏振
— 垂直偏振

■部品规格 Parts specifications

电路板材质 PCB Material	同轴连接器 & 塞孔 Coaxial connector & receptacle	同轴电缆长度 Coaxial cable length
FR-4	I-PEX MHF Series	100mm

用于 2.4GHz 带 For 2.4GHz Band

● UB18CP-100ST01



■特点

- 是安装了贴片天线、匹配电路、同轴连接器的天线单元
- 无需进行电路板设计，减少了开发费用和最初成本

■用途

- 无线 LAN、Bluetooth™ 等
- DECT (1.9GHz)

■Features

- The antenna unit has a chip antenna with a matching circuit and a coaxial cable.
- Full turnkey solution can save time, design and initial cost.

■Applications

- Wireless LAN, Bluetooth™ etc.
- DECT 1.9GHz

■形状・尺寸 Dimensions

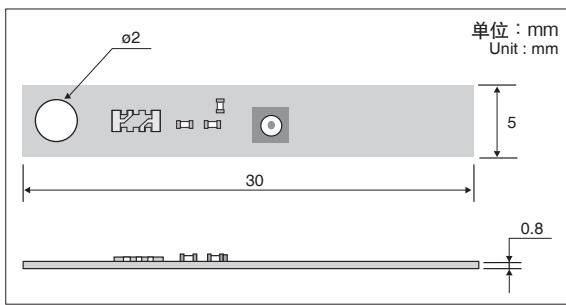

■ V.S.W.R. 的特性及其放射特性 (参考)

V.S.W.R. & radiation characteristics (Reference) :

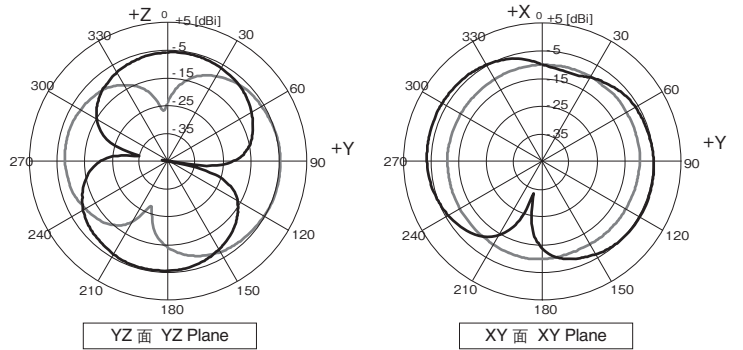
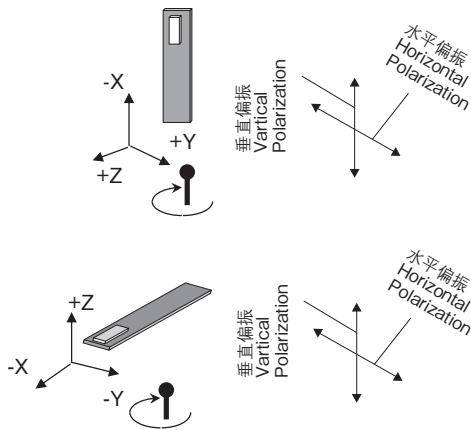
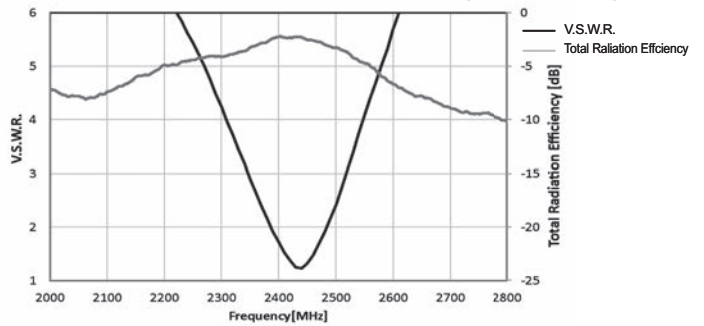

< 频带宽度 Band width >
V.S.W.R. ≤ 3 : 191MHz
< 收益 Gain @2442MHz >
平均 Average : -4.4dBi
最大 Maximum : -1.0dBi

— 水平偏波
— 垂直偏波

■部品规格 Parts specifications

电路板材质 PCB Material	同轴连接器 & 塞孔 Coaxial connector & receptacle	同轴电缆长度 Coaxial cable length
FR-4	I-PEX MHF Series	100mm

贴片天线
CHIP ANTENNAS

用于 2.4&5GHz 带 For 2.4&5GHz Band

● UB23CP-100ST01

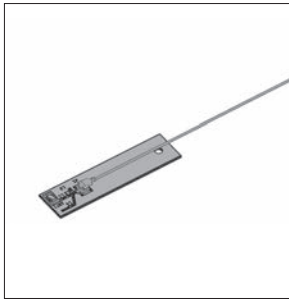

■特点

- 是安装了贴片天线、匹配电路、同轴连接器的天线单元
- 无需进行电路板设计，减少了开发费用和最初成本

■用途

- 无线 LAN

■Features

- The antenna unit has a chip antenna with a matching circuit and a coaxial cable.
- Full turnkey solution can save time, design and initial cost.

■Applications

- Wireless LAN

■形状・尺寸 Dimensions

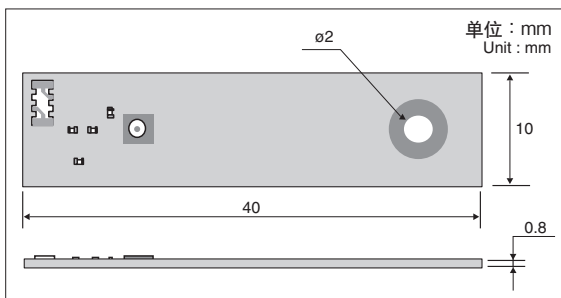

■ V.S.W.R. 的特性及其放射特性 (参考)

V.S.W.R. & radiation characteristics (Reference) :

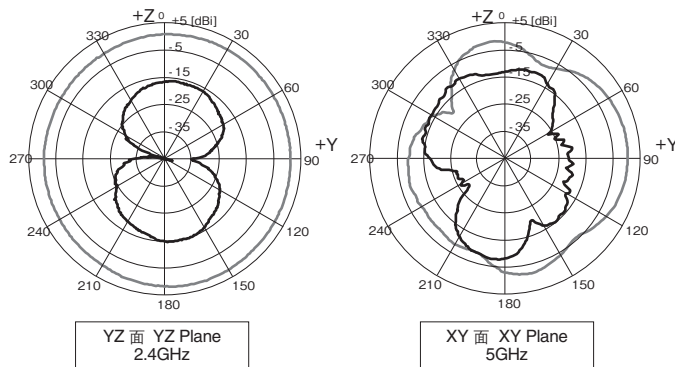
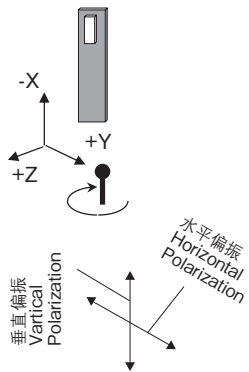
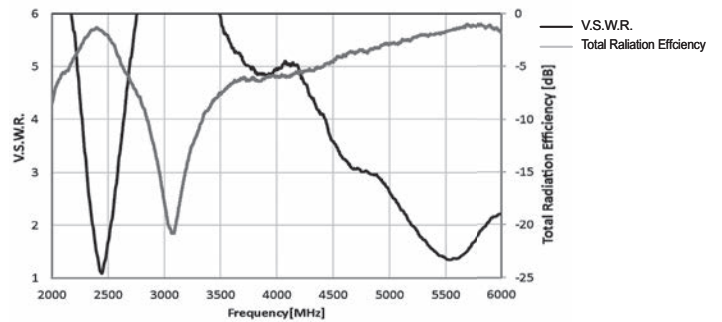

< 频带宽度 Band width >
 @2.4GHz Band
 V.S.W.R. ≤ 3 : 269MHz
 @5GHz Band
 V.S.W.R. ≤ 3 : 1188MHz

< 增益 Gain >
 @2442MHz
 平均 Average : -0.9dBi
 最大 Maximum : +2.1dBi
 @5200MHz
 平均 Average : -2.3dBi
 最大 Maximum : +2.1dBi

—— 水平偏波
 —— 垂直偏波

■部品规格 Parts specifications

电路板材质 PCB Material	同轴连接器 & 塞孔 Coaxial connector & receptacle	同轴电缆长度 Coaxial cable length
FR-4	I-PEX MHF Series	100mm

推荐焊盘布局 (参考)

Recommended Land Pattern (Reference)

电极图形 (主板表面): AM11DP-ST01*
Land pattern (Surface of the Substrate)

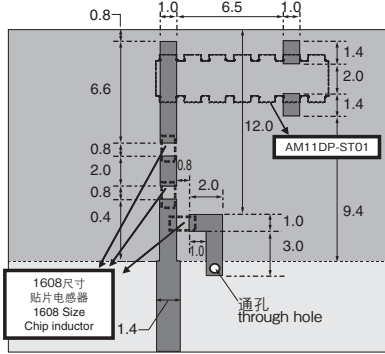

底板全图 (主板表面): AM11DP-ST01*
Evaluated board (Surface of the Substrate)

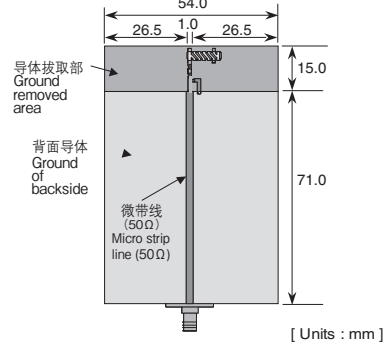

电极图形 (主板表面): AM03DP-ST01*
Land pattern (Surface of the Substrate)

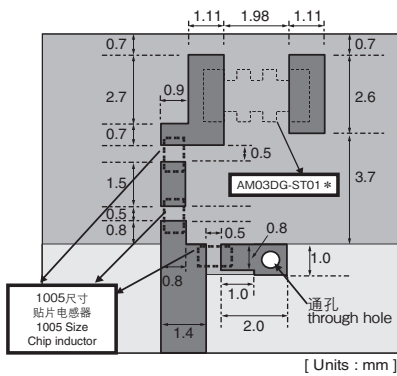

底板全图 (主板表面): AM03DP-ST01*
Evaluated board (Surface of the Substrate)

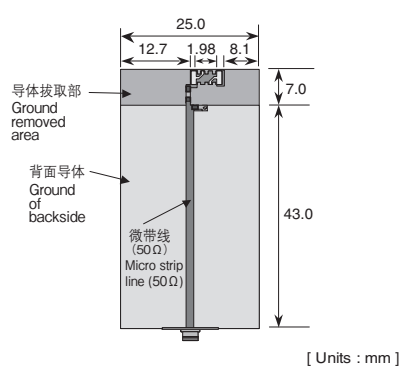

电极图形 (主板表面): AW03DP-245ST01*
Land pattern (Surface of the Substrate)

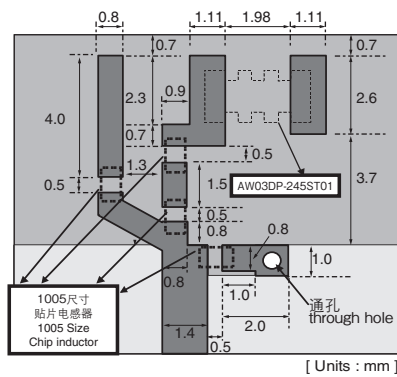

底板全图 (主板表面): AW03DP-245ST01*
Evaluated board (Surface of the Substrate)

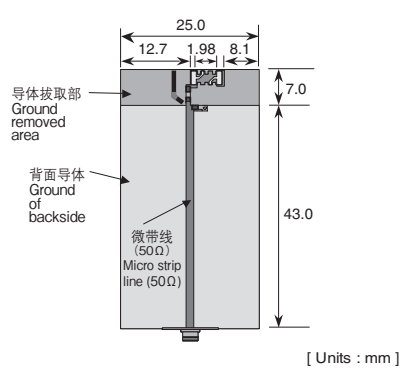

■包装形式 Packing form

单位: mm
Unit: mm

包装记号 Packing code	型号 Part number	包装数量 Packing Qty.	包装形式 Packing form																																	
T	AM11	4,000	<p>圆形馈孔 Circular feed hole</p> <p>零件安装矩形凹孔 Rectangular hole for part loading</p> <p>引出方向 Outfeeding direction</p>	<table border="1"> <tr> <th>A</th> <th>B</th> <th>C</th> <th>D</th> <th>E</th> <th>W₁</th> <th>W₂</th> <th>r</th> </tr> <tr> <td>φ330 +0 -3</td> <td>φ80 +1 -0</td> <td>φ13.0 ±0.2</td> <td>R10.5 ±0.4</td> <td>2.0 ±0.5</td> <td>24.4 ±0.6</td> <td>30.4≥</td> <td>0.5</td> </tr> </table> <table border="1"> <tr> <th>A</th> <th>B</th> <th>E</th> <th>F</th> <th>P0</th> <th>P1</th> <th>W</th> <th>安装孔 Loading hole</th> </tr> <tr> <td>3.3 ±0.1</td> <td>10.8 ±0.1</td> <td>1.75 ±0.1</td> <td>11.5 ±0.1</td> <td>4.0 ±0.1</td> <td>8.0 ±0.1</td> <td>24 ±0.3</td> <td>方形通孔 Rectangular hole</td> </tr> </table>	A	B	C	D	E	W ₁	W ₂	r	φ330 +0 -3	φ80 +1 -0	φ13.0 ±0.2	R10.5 ±0.4	2.0 ±0.5	24.4 ±0.6	30.4≥	0.5	A	B	E	F	P0	P1	W	安装孔 Loading hole	3.3 ±0.1	10.8 ±0.1	1.75 ±0.1	11.5 ±0.1	4.0 ±0.1	8.0 ±0.1	24 ±0.3	方形通孔 Rectangular hole
	A	B	C	D	E	W ₁	W ₂	r																												
φ330 +0 -3	φ80 +1 -0	φ13.0 ±0.2	R10.5 ±0.4	2.0 ±0.5	24.4 ±0.6	30.4≥	0.5																													
A	B	E	F	P0	P1	W	安装孔 Loading hole																													
3.3 ±0.1	10.8 ±0.1	1.75 ±0.1	11.5 ±0.1	4.0 ±0.1	8.0 ±0.1	24 ±0.3	方形通孔 Rectangular hole																													
AM03 AW03	4,000	<p>圆形馈孔 Circular feed hole</p> <p>零件安装矩形凹孔 Rectangular hole for part loading</p> <p>引出方向 Outfeeding direction</p>	<table border="1"> <tr> <th>A</th> <th>B</th> <th>C</th> <th>D</th> <th>E</th> <th>W₁</th> <th>W₂</th> <th>r</th> </tr> <tr> <td>φ180.0 +0 -3</td> <td>φ60 +1 -0</td> <td>φ13.0 ±0.2</td> <td>R10.5 ±0.4</td> <td>2.0 ±0.5</td> <td>9.0 ±0.3</td> <td>11.4 ±1.0</td> <td>0.5</td> </tr> </table> <table border="1"> <tr> <th>A</th> <th>B</th> <th>E</th> <th>F</th> <th>P0</th> <th>P1</th> <th>W</th> <th>安装孔 Loading hole</th> </tr> <tr> <td>1.9 ±0.1</td> <td>3.5 ±0.1</td> <td>1.75 ±0.1</td> <td>3.5 ±0.05</td> <td>4.0 ±0.1</td> <td>4.0 ±0.1</td> <td>8.0 ±0.2</td> <td>方形通孔 Rectangular hole</td> </tr> </table>	A	B	C	D	E	W ₁	W ₂	r	φ180.0 +0 -3	φ60 +1 -0	φ13.0 ±0.2	R10.5 ±0.4	2.0 ±0.5	9.0 ±0.3	11.4 ±1.0	0.5	A	B	E	F	P0	P1	W	安装孔 Loading hole	1.9 ±0.1	3.5 ±0.1	1.75 ±0.1	3.5 ±0.05	4.0 ±0.1	4.0 ±0.1	8.0 ±0.2	方形通孔 Rectangular hole	
A	B	C	D	E	W ₁	W ₂	r																													
φ180.0 +0 -3	φ60 +1 -0	φ13.0 ±0.2	R10.5 ±0.4	2.0 ±0.5	9.0 ±0.3	11.4 ±1.0	0.5																													
A	B	E	F	P0	P1	W	安装孔 Loading hole																													
1.9 ±0.1	3.5 ±0.1	1.75 ±0.1	3.5 ±0.05	4.0 ±0.1	4.0 ±0.1	8.0 ±0.2	方形通孔 Rectangular hole																													
B	全产品 All types	100	<p>塑料袋 Plastic bag</p>																																	

■使用注意事项

●适用温度范围

使用温度范围：-40°C ~ +85°C

保存温度范围：-40°C ~ +85°C

●操作主要事项

产品是陶瓷产品，过度的冲击、过重的压力施加等都可能破坏元件。

关于单体和电路板搭载后的操作、运输等，请充分注意。

●保管方法

请在密封状态（盖带未开封）下，保存在常温常湿的环境中。但是，如果保存在以下环境中，产品特性可能发生劣化，敬请注意。

- 特殊气体（SOx、NOx、Cl₂、NH₃等）
- 灰尘较多的场所、多湿，容易结露的场所

请在交货后3个月内使用。此外，盖带开封后，请尽快使用。

如果保存期间超过3个月，在使用前，请确认可焊性。

※推荐保管条件

温度：-10°C ~ +40°C

湿度：15%R.H ~ 85%R.H

●PCB设计方面的注意事项

- 搭载天线的领域必须拔出铜箔（GND）。
- 在拔出GND的领域，请勿安装其他任何类型的电子零件。
- 无线机PCB为2段或3段结构时，请拔下天线安装处上方（下方）电路板上的GND。

●树脂涂层的影响

- 根据树脂的具体种类，在硬化过程或自然放置的状态下，树脂的分解气体或反应气体可能会聚集在树脂内部，造成产品性能劣化。
- 如果树脂的硬化温度超过产品的使用温度，或受到热膨胀收缩力更大的影响，可能会造成产品损坏。
- 根据树脂的热膨胀收缩应力，可能会造成产品性能劣化，因此请勿使用这类树脂。
- 建议使用吸湿性较弱的电路板（例：玻璃环氧树脂材料）。

如果使用了吸湿性较强的电路板，电路板的吸湿可能会对天线特性造成影响。

●附近金属结构材料的影响

- 金属结构材料靠近天线后，天线性能会出现明显的劣化。如果有金属结构材料靠近天线，请尽可能确保两者之间的距离。

●人体的影响

- 由于天线的共振频率在受到人体影响后，会转入低频率区域，因此在用于遥控器等产品时，请进行调整，确保在与人体接触时，能够获得最佳的特性。

●框体的影响

- 实际的无线终端的电路板会被放入塑料制框体内。由于天线的共振频率在受到该框体的影响后，会转入低频率区域，因此请将电路板放入框体内。
- 如果将安装了天线的电路板放入金属框体，天线会失去功能，请勿进行上述操作。

Precautions

● Operating temperature range

Operating temperature range : -40°C ~ +85°C

Storage temperature range : -40°C ~ +85°C

● Handling

Excessive stress or mechanical shock may damage to products, therefore, please be careful in handling or transporting products and assemblies with this product.

● Storage

Products should be stored as it packaged (as sealed up) under normal temperature and humidity. To avoid degradation or destruction of products, please do not store under conditions below.

- In an atmosphere containing corrosive gas (SOx, NOx, Cl₂, NH₃ etc.)
- Dusty Place
- Humid place, where water condenses

Stored products should be used within 3 months of receipt (If once the seal of covertape is broken, please use immediately).

If this period is exceeded please verify solderability of products.

[Recommended storage condition]

Temperature : -10°C ~ +40°C

Humidity : 15%R.H ~ 85%R.H

● Instruction for designing PCB

- The area an antenna is put on has to strip copper foil (GND).
- Any kind of electric part is not allowed to place this GND stripped area except for the antenna elements.
- If the circuit board has 2 or 3 stage structure and the antenna is mounted on one of them, not only the antenna mounted PCB but also the other PCB should have GND stripped areas around the antenna so as not to shield the radiation from the antenna towards any directions.

● The influence of resin coating

- Decomposition gas or chemical reaction vapor of some type of resins may remain inside the resin during the hardening period or normal storage, resulting in deterioration of the performance of the products.
- When a hardening temperature of resin is higher than the operating temperature, the stresses generated by the excess heat may lead to damage or destruction of the product.
- Stress caused by a resin's temperature generated expansion and contraction may damage the products. The use of such resins, molding materials etc. is not recommended.
- We recommend the use of a low hygroscopic board(ex : Glass epoxy matrix) .If you used a high hygroscopic board, it may have an influence on an antenna characteristic because a board absorbs moisture.

● The influence of a metal structure approaching

- When metal structure was arranged near an antenna, the characteristic becomes remarkably bad. In that case, please keep distance as much as possible.

● The influence of the human body

- Antenna resonance frequency shifts towards lower frequency under the influence of the human body. So if the antenna is applied to the remote controller and so on, which mainly works in contact with the human body; antenna should be tuned under the condition of touching the human body.

● The influence of the casing

- In a practical wireless terminal, a circuit board will be enclosed in a case made of plastic. This plastic case has a tendency to make resonance frequency shift lower. Therefore in this case; tuning should be done under the condition where the circuit board is enclosed in the plastic case.
- When you case the board which put on an antenna in a metal casing, the function of the antenna will be lost. Please do not perform it.

型号 Part number	焊接条件 Soldering conditions
CSA20 CSA30 CSA70 CDA70 TH03 TX03 TN05 TC05 TH05 TD05 TX05 TZ05 TN11 TH11 TD11 TN10 TC10 TN20 TC20 TH20 MN18 MH18 GA13 GA20 GH13 GH20 ※2	<p>推荐温度曲线 Recommended Temperature Profile</p> <p>流体焊接 Flow soldering conditions 共晶焊接时 Eutectic Solder</p> <p>无铅焊接时 Lead free Solder</p> <ol style="list-style-type: none"> 1) 保持时间为元件表面温度达到上述温度后起算的时间。 2) ΔT应在100°C以内。 3) 焊接后切勿迅速冷却，而应缓慢冷却。 <ol style="list-style-type: none"> 1) Time shown in the above figures is measured from the point when chip surface reaches temperature. 2) Temperature difference in high temperature part should be within 100°C. 3) After soldering, do not force cool, allow the parts to cool gradually.
	<p>回流焊接 Reflow soldering conditions 共晶焊接时 Eutectic Solder</p> <p>无铅焊接时 Lead free Solder</p> <ol style="list-style-type: none"> 1) 保持时间为元件表面温度达到上述温度后起算的时间。 2) ΔT应在100°C以内。 3) 焊接后切勿迅速冷却，而应缓慢冷却。 <ol style="list-style-type: none"> 1) Time shown in the above figures is measured from the point when chip surface reaches temperature. 2) Temperature difference in high temperature part should be within 100°C. 3) After soldering, do not force cool, allow the parts to cool gradually. <p>※1 仅可进行回流焊接 ※2 仅为镀锡品或仅适用于流动焊接。 其它产品请在规格书所记载的条件下使用。</p>
AM11 ※1 AM03 ※1	<p>※1 Reflow only ※2 Tin plated only, and flow only. Soldering method of the other products refer to the individual specification.</p>

【焊接时的一般注意事项】

- 若焊接温度过高,焊接时间过长,端子电极处可能会发生浸析,从而导致粘着力下降或性能劣化。
- 焊接时请参照上述温度曲线进行。但超过200°C的温度应控制在50秒以内。
- 焊剂应使用低活性(Cl含有率在0.2wt%以下)的产品。如果焊剂为水溶性,且清洗不充分的话,可能会损伤元件下部的绝缘,应予以注意。

【清洗】

用超声波进行清洗时,输出过大会引起主板共振,振动可能会造成主板破裂或端子电极粘着力下降。故此,推荐按以下条件进行清洗。

频率:40kHz以下
输出:20W/l
清洗时间:5分钟以内

General attention to soldering

- High soldering temperatures and long soldering times can cause leaching of the termination, decrease in adherence strength, and the change of characteristic may occur.
- For soldering, please refer to the soldering curves above. However, please keep exposure to temperatures exceeding 200°C to under 50 seconds.
- Please use a mild flux(containing less than 0.2wt% Cl). Also, if the flux is water soluble, be sure to wash thoroughly to remove any residue from the underside of components, that could affect resistance.

Cleaning

When using ultrasonic cleaning, the board may resonate if the output power is too high. Since this vibration can cause cracking or a decrease in the adherence of the termination, we recommend that you use the conditions below.

Frequency:40kHz max.
Output power:20W/liter
Cleaning time:5minutes max.